

ADJUSTABLE STEEL GANTRY CRANE - AHS-6-15-10

APPROX WEIGHT: 882.71 lbs.
 DOES NOT INCLUDE WEIGHT OF POWER OR PACKAGING!!!

*** ANY ADDITIONS, DELETIONS, OR OMISSIONS MUST BE CORRECTED ON THIS DRAWING AS THIS DRAWING WILL BE CONSIDERED ALL INCLUSIVE ***
 ALL GRAPHICS PROVIDED ARE FOR REFERENCE ONLY. IF CERTAIN DIMENSIONS ARE CRITICAL PLEASE VERIFY THOSE DIMENSIONS WITH YOUR SALESPERSON

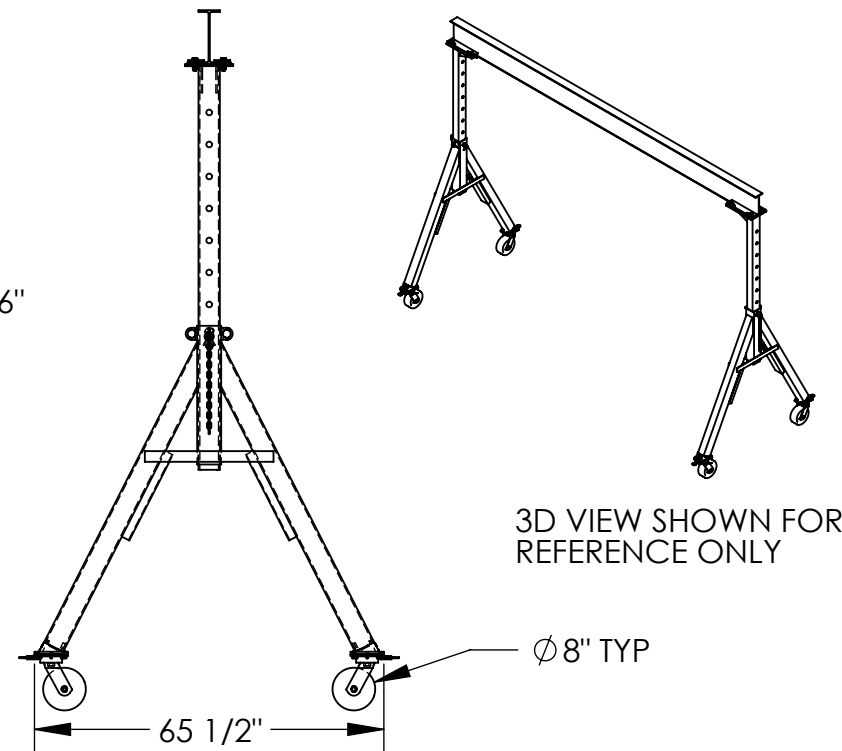
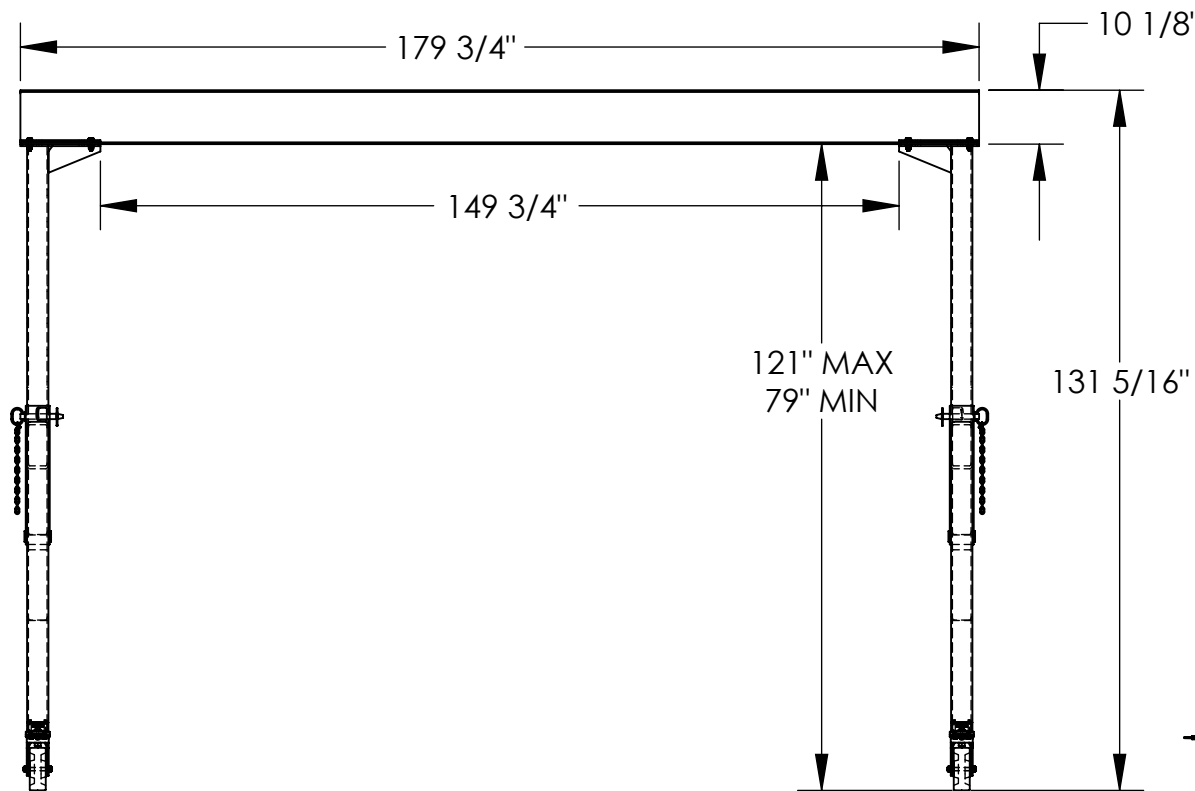

3D VIEW SHOWN FOR REFERENCE ONLY

DIMENSION TOLERANCE $\pm 1/4$ "

STANDARD FEATURES

- MODEL NUMBER IS AHS-6-15-10
- CAPACITY IS 6,000 LBS.
- BASE WIDTH IS 65 1/2"
- OVERALL HEIGHT IS 131 5/16"
- OVERALL I-BEAM LENGTH IS 179 3/4"
- USABLE I-BEAM LENGTH IS 149 3/4"
- ADJUSTABLE UNDER I-BEAM HEIGHT
 - 121" MAX
 - 79" MIN
- I-BEAM HEIGHT IS 10 1/8"
- (4) Ø8" SWIVEL CASTERS WITH FOUR LOCKING POSITIONS

SPECIAL FEATURES

NONE

A P P R O V A L

I, THE UNDERSIGNED, AGREE THAT THE PRODUCT AS REPRESENTED SATISFIES DESIGN AND DIMENSION REQUIREMENTS. I ALSO ACKNOWLEDGE MY DUTY TO CONFIRM PRODUCT AND INSTALLATION COMPLIANCE WITH ALL APPLICABLE FEDERAL, STATE AND LOCAL REGULATIONS AND STANDARDS.

ALL SPECIAL UNITS ARE NON-RETURNABLE
 As drawn As marked

Signed: _____ Date: _____

LEAD TIME WILL START UPON RECEIPT OF SIGNED APPROVAL DRAWING

FOR INTERNAL USE ONLY PROJECT SIGN OFF	
SALES	
ENG.	
FAB.	
POWER	

DISTRIBUTOR'S NAME:		P.O.#
VESTIL MANUFACTURING		X
DRAWN BY: ND	DATE: 10/12/09	W.O.#
REFERENCE: X	SCALE: 1:36	X
QUOTED LEAD TIME: X	QUOTE #	FILE NAME:
	X	28-007-208