

EXP-20

REVISION: S
ECO NO.: 2567
BY: G. REEDER
DATE: 12/13/07

COXREELS SERIES T

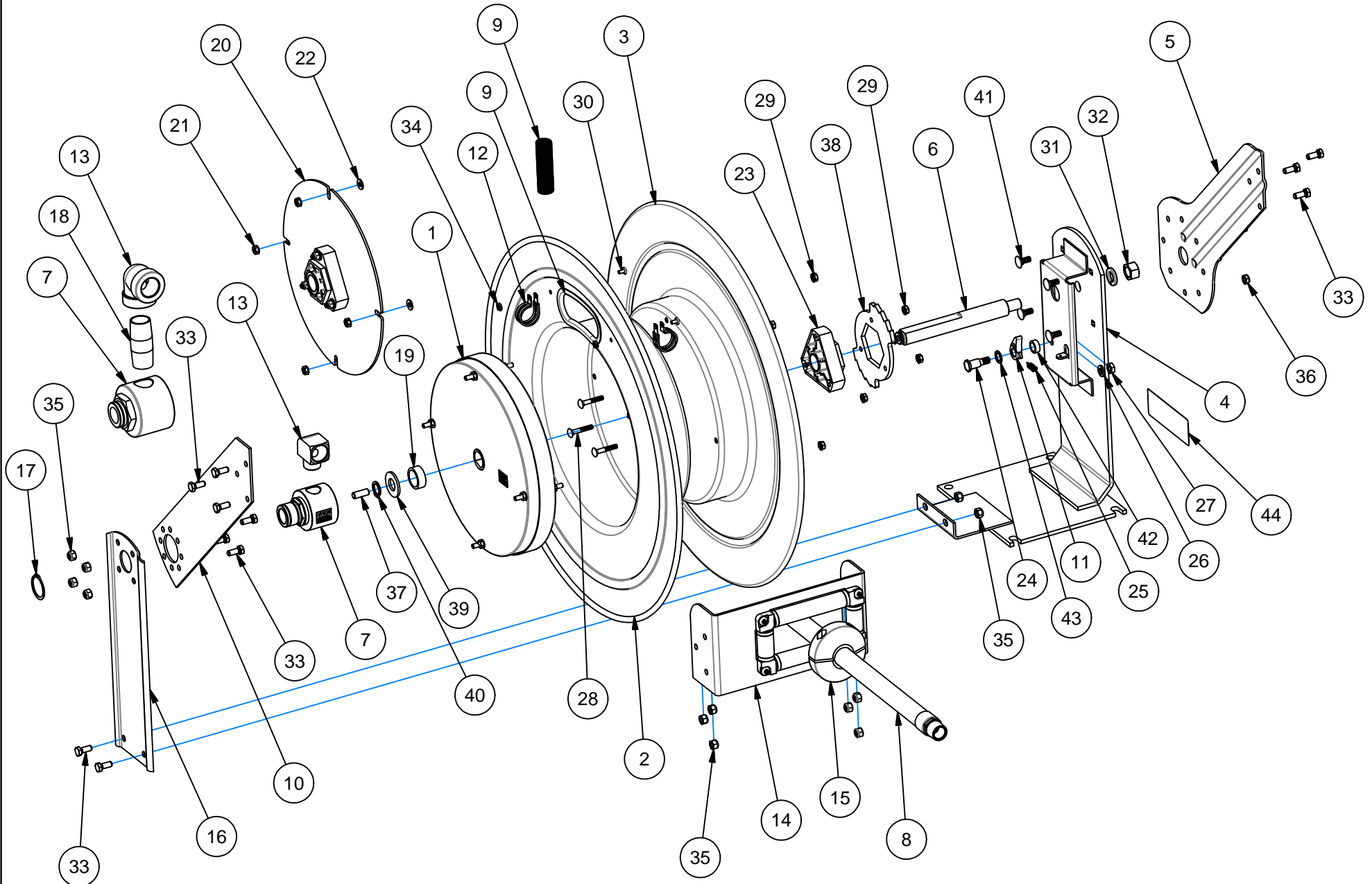

ITEM	PART	DESCRIPTION	QTY
23	1776-3	ASSEMBLY: 1" HUB BEARING	1
24	1620	BOLT: SHOULDER, 1/2"x1 1/2"	1
25	274-1-SS	SPRING: LOCK DOG	1
26	437	WASHER: 3/8" LOCK	1
27	184	NUT: 3/8-16 JAM	1
28	1953	BOLT: 1/4-20 x 1 1/2" CARRIAGE	3
29	125	NUT: 1/4-20 KEPS	7
30	245	SCREW: #10-32 x 3/8"	2
31	438	WASHER: 5/8" LOCK	1
32	3584	NUT: 5/8-11 HEX	1
33	312	BOLT: 5/16-18 x 3/4" HEX	12

ITEM	PART	DESCRIPTION	QTY
34	130	NUT: 10-32 KEPS	2
35	111	NUT: 5/16-18 NYLOCK	12
36	111-1	NUT:5/16-18 NYLOCK (LOW PROFILE)	4
37	10235-SS	STUD: 3/8-16 x 1" SS	1
38	1924	RING: LOCKING	1
39	1755-1	WASHER: SPACER	1
40	1753	RING: #5160-75 RETAINING	1
41	10220-75	BOLT: 5/16"-18 x 3/4" CARRIAGE	4
42	6440-SS	WASHER: SPACER SS	1
43	6441-1	WASHER: SPACER	1
44	10925-5	LABEL: STANDARD PRODUCT	1

ITEM NUMBER

MODEL	ITEM NUMBER								ITEM NUMBER															
	1	2	3	4	5	6	7	* 8	* 9	10	11	12	13	14	* 15	16	17	18	19	20	21	22		
	SPRING	DRUM	DRUM	BASE	ARM	AXLE	SWIVEL	HOSE (STD)	HOSE (-OG)	HOSE (-RH)	GUARD	ARM	L. CAM	CLAMP (2)	ELBOW	BRKT.	BALL ST	SUPP.	R.RING	NIPPLE	SPACER	SUPP. BRG.	NUT (4)	WASHER (4)
TSH-N-350	690-2	1703	1702	1784	1732	1794	433	5153-50	5101-50	5045-50	237-1	1827	640-1-SS	381	-	1829-1	131-3	1740	1754	-	7511	-	-	-
TSH-N-375	698-1	1705	1704	1786	1733	1794	433	5153-75	5101-75	5045-75	237-1	1825	640-1-SS	381	-	1829-1	131-3	1741	1754	-	7511	-	-	-
TSH-N-3100	698-2	1705	1704	1786	1733	1794	433	5153-100	5101-100	5045-100	237-1	1825	640-1-SS	381	-	1829-1	131-3	1741	1754	-	7511	-	-	-
TSH-N-3125	652	1705	1704	1786	1733	1794	433	5153-125	5101-125	5045-125	237-1	1825	640-1-SS	381	-	1829-1	131-3	1741	1754	-	-	-	-	-
TSH-N-450	691-3	1703	1702	1784	1732	1794	434	5154-50	5131-50	5066-50	398-1	1827	640-1-SS	383	-	1829-1	131-4	1740	1754	-	7511	-	-	-
TSH-N-475	692-2	1705	1704	1786	1733	1794	434	5154-75	5131-75	5066-75	398-1	1825	640-1-SS	383	-	1829-1	131-4	1741	1754	-	-	-	-	-
TSH-N-4100	656	1705	1704	1786	1733	1794	434	5154-100	5131-100	5066-100	398-1	1825	640-1-SS	383	-	1829-1	131-4	1741	1754	-	-	-	-	-
TSH-N-535	695-1	1705	1704	1786	1733	1794	426	5155-35	5163-35	5091-35	398-1	1825	640-1-SS	384	385	8740	430	1712	516	-	7511	-	-	-
TSHF-N-535	695-1	1705-1	1704	1786	1733	1794	426	5097-35	-	-	398-1	1825	640-1-BR	384	385	8740	430	1712	516	-	7511	-	-	-
TSH-N-550	692-1	1705	1704	1786	1733	1794	426	5155-50	5163-50	5091-50	398-1	1825	640-1-SS	384	385	8740	430	1712	516	-	-	-	-	-
TSHF-N-550	692-1	1705-1	1704	1786	1733	1794	426	5097-50	-	-	398-1	1825	640-1-BR	384	385	8740	430	1712	516	-	-	-	-	-
TSH-N-575	8729-1	7238-1	7239	8726	1733	8728	426	5155-75	5163-75	5091-75	7242	1825	640-1-SS	384	385	8731	430	1712	516	-	-	8724	125	688
TSHF-N-575	8729-1	7238-1	7239	8726	1733	8728	426	5097-75	-	-	7242	1825	640-1-BR	384	385	8731	430	1712	516	-	-	8724	125	688
TSH-N-635	649	7238	7239	7237	1733	1794	7231-1	5096-35	-	-	7242	7232	640-1-SS	397	15338-G	8737	20214	7233	7241	7240	-	-	-	-
TSHF-N-635	649	7238	7239	7237	1733	1794	7231-1	5092-35	-	-	7242	7232	640-1-BR	397	15338-G	8737	20214	7233	7241	7240	-	-	-	-
TSH-N-650	8729	7238-1	7239	8726	1733	8728	7231-1	5096-50	-	-	7242	7232	640-1-SS	397	15338-G	8731	20214	7233	7241	7240	-	8724	125	688
TSHF-N-650	8729	7238-1	7239	8726	1733	8728	7231-1	5092-50	-	-	7242	7232	640-1-BR	397	15338-G	8731	20214	7233	7241	7240	-	8724	125	688

ITEM NUMBER

MODEL	ITEM NUMBER								ITEM NUMBER														
	1	2	3	4	5	6	7	* 8	* 9	10	11	12	13	14	* 15	16	17	18	19	20	21	22	
	SPRING	DRUM	DRUM	BASE	ARM	AXLE	SWIVEL	HOSE (STD)	GUARD	ARM	L. CAM	CLAMP (2)	ELBOW	BRKT.	BALL ST	SUPP.	R.RING	NIPPLE	SPACER	SUPP. BRG.	NUT (4)	WASHER (4)	
TMP-N-350	699-1	1703	1702	1784	1732	1794	433	5224-50	237-1	1827	640-1-SS	381	-	1829-1	131-3	1740	1754	-	7511	-	-	-	-
TMP-N-375	656	1705	1704	1786	1733	1794	433	5224-75	237-1	1825	640-1-SS	381	-	1829-1	131-3	1741	1754	-	-	-	-	-	-
TMP-N-3100	657	1705	1704	1786	1733	1794	433	5224-100	237-1	1825	640-1-SS	381	-	1829-1	131-3	1741	1754	-	-	-	-	-	-
TMP-N-450	649	1703	1702	1784	1732	1794	434	5256-50	398-1	1827	640-1-SS	383	-	1829-1	131-4	1740	1754	-	-	-	-	-	-
TMP-N-475	656	1705	1704	1786	1733	1794	434	5256-75	398-1	1825	640-1-SS	383	-	1829-1	131-4	1741	1754	-	-	-	-	-	-
TMP-N-4100	658	1705	1704	1786	1733	1794	434	5256-100	398-1	1825	640-1-SS	383	-	1829-1	131-4	1741	1754	-	-	-	-	-	-
TMP-N-525	691-1	1703	1702	1784	1732	1794	426	5290-25	398-1	1827	640-1-SS	384	385	8740	430	1711	516	-	7511	-	-	-	-
TMP-N-535	654	1705	1704	1786	1733	1794	426	5290-35	398-1	1825	640-1-SS	384	385	8740	430	1712	516	-	-	-	-	-	-
TMP-N-550	654	1705	1704	1786	1733	1794	426	5290-50	398-1	1825	640-1-SS	384	385	8740	430	1712	516	-	-	-	-	-	-
TMP-N-575	8734-1	7238-1	7239	8726-1	1733	8733	426	5290-75	7242	1825	640-1-SS	384	385	8721	430	1712	516	-	-	8724	125	688	
TMP-N-650	8734	7238-1	7239	8726-1	1733	8733	7231-1	5093-50	7242	7232	640-1-SS	397	15348	8721	20214	7233	7241	-	-	8724	125	688	

ITEM NUMBER

MODEL	ITEM NUMBER								ITEM NUMBER														
	1	2	3	4	5	6	7	* 8	* 9	10	11	12	13	14	* 15	16	17	18	19	20	21	22	
	SPRING	DRUM	DRUM	BASE	ARM	AXLE	SWIVEL	HOSE (STD)	GUARD	ARM	L. CAM	CLAMP (2)	ELBOW	BRKT.	BALL ST	SUPP.	R.RING	NIPPLE	SPACER	SUPP. BRG.	NUT (4)	WASHER (4)	
THP-N-150	647	1703	1702	1784	1732	1794	499	5304-50	237-1	1827	640-1-SS	115	-	1829-1	131	1740	1754	-	7511	-	-	-	-
THP-N-175	698-3	1705	1704	1786	1733	1794	499	5304-75	237-1	1825	640-1-SS	115	-	1829-1	131	1741	1754	-	7511	-	-	-	-
THP-N-1100	657	1705	1704	1786	1733	1794	499	5304-100	237-1	1825	640-1-SS	115	-	1829-1	131	1741	1754	-	-	-	-	-	-
THP-N-350	696-1	1703	1702	1784	1732	1794	521	5336-50	237-1	1827	640-1-SS	613	-	1829-1	131-3	1740	1754	-	-	-	-	-	-
THP-N-375	656	1705	1704	1786	1733	1794	521	5336-75	237-1	1825	640-1-SS	613	-	1829-1	131-3	1741	1754	-	-	-	-	-	-

* ON "LESS HOSE" MODELS (TSHL-/TMPL-/THPL-) EXCLUDE ITEMS #8, #9, AND #15.
 NOTE: MODELS SUPPLIED WITH "STANDARD" HOSE UNLESS SUFFIXED WITH "-OG" OR "-RH". USE HOSE NUMBERS AS NOTED ABOVE.

REEL ASSEMBLY REPORTS: R100 (LATCHOUT REMOVAL), R101 (LOCKING RING PLACEMENT), R112 (TIGHTENING AND TORQUING)

REVISION: S ECO: 2567 DATE: 12/13/07 NAME: G. REEDER

EXP-10.DWG

REVISION: T

ECO NO.: 2158-1

DRAWN BY: M. LLOYD

DATE: 05/11/05

COXREELS

SERIES P

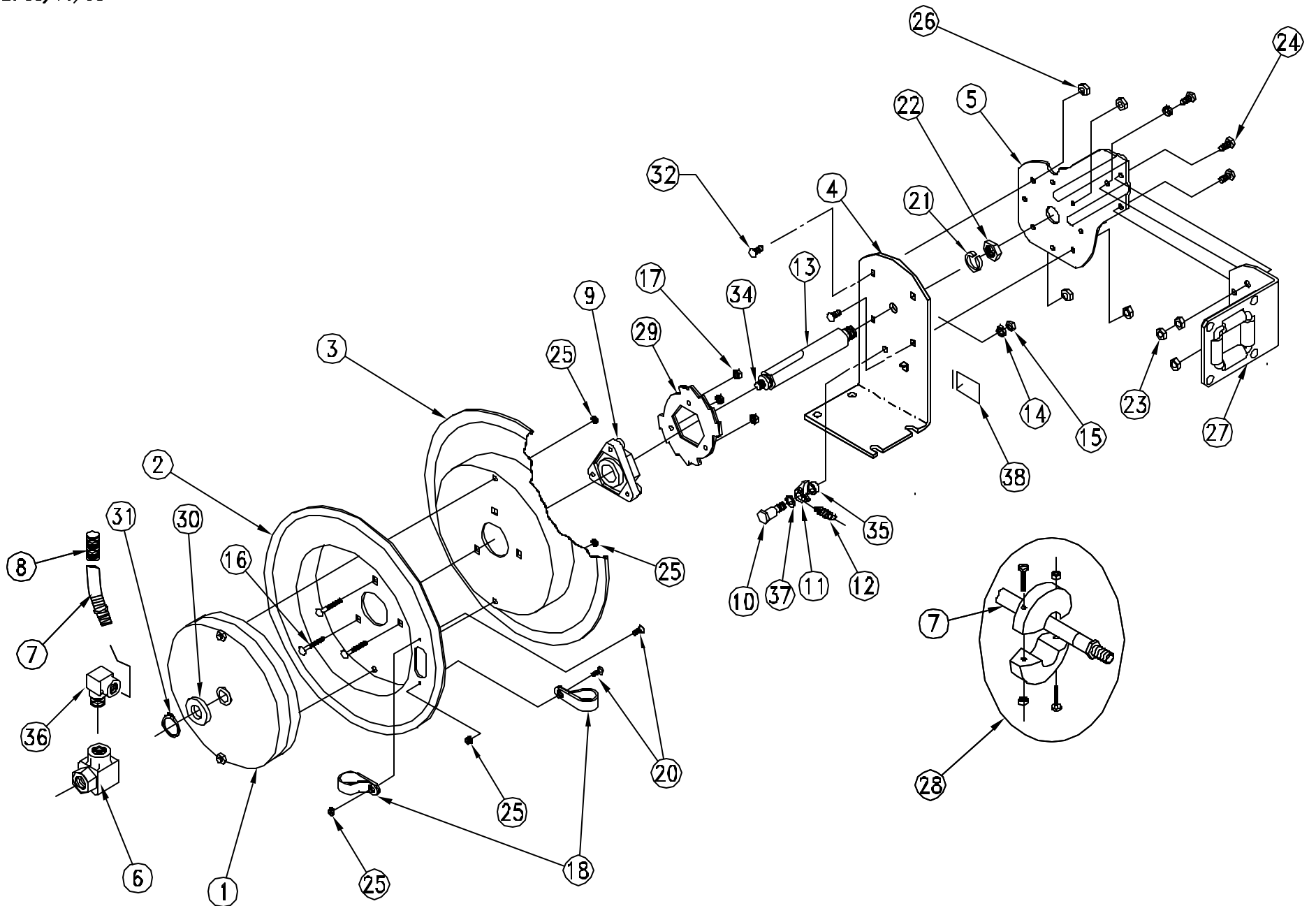

ITEM NO.	PART NO.	DESCRIPTION	QTY REQ'D
9	1776-3	ASSY., HUB BEARING	1
10	1620	BOLT, SHOULDER, 1/2"x1-1/2"	1
11	640-1-SS	CAM, LOCKING	1
12	274-1-SS	SPRING, DOG	1
14	437	WASHER, LOCK, 3/8"	1
15	184	NUT, JAM, 3/8-16	1
16	1953	CARRIAGE BOLT, 1/4-20 x 1.5	3
17	125	NUT, KEPS, 1/4-20	3
20	245	SCREW, TRUSS HD. 10-32x3/8"	2
21	438	WASHER, LOCK, 5/8"	1
22	3584	NUT, 5/8-11	1
23	111	NUT, LOCK, 5/16-18	3

ITEM NO.	PART NO.	DESCRIPTION	QTY REQ'D
24	312	BOLT, 5/16-18"	3
25	130	NUT, KEPS, 10-32	4
26	111-1	NUT, LOCK, 5/16-18, LOW PROF	4
29	1924	LOCKING RING	1
30	1755-1	WASHER, SPACER	1
31	1753	RETAINING RING (5160-75)	1
32	10220-75	BOLT, CARRIAGE, 5/16-18x3/4"	4
34	10235-SS	SETSCREW 3/8-16x1" CUP PT-SS	1
35	6440-SS	WASHER, SPACER	1
37	6441-1	WASHER, SPACER	1
38	10925-5	LABEL	1

ITEM NUMBER

MODEL NO.	ITEM NUMBER														
	1 SPRING	2 DRUM	3 DRUM	4 BASE	5 ARM	6 SWIVEL	* 7 HOSE (STD)	* 7 HOSE (-OG)	* 7 HOSE (-RH)	* 8 HOSE GRD	13 AXLE	18 CLAMP	27 ROLLER B.	* 28 BALL STOP	36 ELBOW
P-LP-110	1959-1	139-1	140-1	1954	1732-1	1969	5150-10	5121-10	3870-10	237-1	1956	2169	1728-2	131	-
P-LP-115	1959-2	139-1	140-1	1954	1732-1	1969	5150-15	5121-15	3870-15	237-1	1956	2169	1728-2	131	-
P-LP-125	1959-3	139-1	140-1	1954	1732-1	1969	5150-25	5121-25	3870-25	237-1	1956	2169	1728-2	131	-
P-LP-130	1959-4	139-1	140-1	1954	1732-1	1969	5150-30	5121-30	3870-30	237-1	1956	2169	1728-2	131	-
P-LP-135	1959-5	139-1	140-1	1954	1732-1	1969	5150-35	5121-35	3870-35	237-1	1956	2169	1728-2	131	-
P-LP-140	689-4	1948	1947	1970	1732-2	1969	5150-40	5121-40	3870-40	237-1	1956	2169	1728-3	131	-
P-LP-150	689-5	1948	1947	1970	1732-2	1969	5150-50	5121-50	3870-50	237-1	1956	2169	1728-3	131	-
P-LP-310	1959-1	139-1	140-1	1954	1732-1	1935	5153-10	5101-10	5045-10	237-1	1956	381	1728-2	131-3	-
P-LP-315	1959-2	139-1	140-1	1954	1732-1	1935	5153-15	5101-15	5045-15	237-1	1956	381	1728-2	131-3	-
P-LP-325	1958-7	139-1	140-1	1954	1732-1	1935	5153-25	5101-25	5045-25	237-1	1956	381	1728-2	131-3	-
P-LP-330	689-3	1948	1947	1970	1732-2	1935	5153-30	5101-30	5045-30	237-1	1956	381	1728-3	131-3	-
P-LP-335	689-3	1948	1947	1970	1732-2	1935	5153-35	5101-35	5045-35	237-1	1956	381	1728-3	131-3	-
P-LP-340	689-4	1948	1947	1970	1732-2	1935	5153-40	5101-40	5045-40	237-1	1956	381	1728-3	131-3	-
P-LP-350	1961-7	1948	1947	1970	1732-2	1935	5153-50	5101-50	5045-50	237-1	1956	381	1728-3	131-3	-
P-LP-415	689-1	1948	1947	1970	1732-2	439	5154-15	5131-15	5066-15	398-1	1956	383	1728-3	131-4	-
P-LP-425	689-2	1948	1947	1970	1732-2	439	5154-25	5131-25	5066-25	398-1	1956	383	1728-3	131-4	-
P-LP-430	1961-5	1948	1947	1970	1732-2	439	5154-30	5131-30	5066-30	398-1	1956	383	1728-3	131-4	-
P-LP-450	2037-6	1948-1	1947	1970	1732-2	439	5154-50	5131-50	5066-50	398-1	1956	383	1829-2	131-4	-

ITEM NUMBER

MODEL NO.	ITEM NUMBER								* 8 HOSE GRD	13 AXLE	18 CLAMP	27 ROLLER B.	* 28 BALL STOP	36 ELBOW
	1 SPRING	2 DRUM	3 DRUM	4 BASE	5 ARM	6 SWIVEL	* 7 HOSE (STD)							
P-MP-320	2037-4	1948	1947	1970	1732-2	1935	5224-20	237-1	1956	381	1728-3	131-3	500	
P-MP-325	2037-3	1948	1947	1970	1732-2	1935	5224-25	237-1	1956	381	1728-3	131-3	500	
P-MP-330	2037-2	1948	1947	1970	1732-2	1935	5224-30	237-1	1956	381	1728-3	131-3	500	
P-MP-335	2037-1	1948	1947	1970	1732-2	1935	5224-35	237-1	1956	381	1728-3	131-3	500	
P-MP-420	2037-4	1948	1947	1970	1732-2	434	5256-20	398-1	1956	383	1728-3	131-4	1671	
P-MP-425	2037-3	1948	1947	1970	1732-2	434	5256-25	398-1	1956	383	1728-3	131-4	1671	
P-MP-430	2037-2	1948	1947	1970	1732-2	434	5256-30	398-1	1956	383	1728-3	131-4	1671	

ITEM NUMBER

MODEL NO.	ITEM NUMBER								* 8 HOSE GRD	13 AXLE	18 CLAMP	27 ROLLER B.	* 28 BALL STOP	36 ELBOW
	1 SPRING	2 DRUM	3 DRUM	4 BASE	5 ARM	6 SWIVEL	* 7 HOSE (STD)							
P-HP-120	2037-4	1948	1947	1970	1732-2	499	5304-20	237-1	1956	115	1728-3	131	616	
P-HP-125	2037-3	1948	1947	1970	1732-2	499	5304-25	237-1	1956	115	1728-3	131	616	
P-HP-130	2037-2	1948	1947	1970	1732-2	499	5304-30	237-1	1956	115	1728-3	131	616	
P-HP-135	2037-1	1948	1947	1970	1732-2	499	5304-35	237-1	1956	115	1728-3	131	616	
P-HP-320	2037-4	1948	1947	1970	1732-2	521	5336-20	237-1	1956	613	1728-3	131-3	617	
P-HP-325	2037-3	1948	1947	1970	1732-2	521	5336-25	237-1	1956	613	1728-3	131-3	617	
P-HP-330	2037-2	1948	1947	1970	1732-2	521	5336-30	237-1	1956	613	1728-3	131-3	617	

* ON "LESS HOSE" MODELS (P-LPL-/P-MPL-/P-HPL-) EXCLUDE ITEMS #7,#8, AND #28.
 NOTE: MODELS SUPPLIED WITH "STANDARD" HOSE UNLESS SUFFIXED WITH "-OG" OR "-RH". USE HOSE NUMBERS AS NOTED ABOVE.

REEL ASSEMBLY REPORTS: R100 (LATCHOUT REMOVAL), R101 (LOCKING RING PLACEMENT), R112 (TIGHTENING AND TORQUING)