

ELECTRIC HYDRAULIC TRASH CAN DUMPER - TCD-M-60-AC

APPROX WEIGHT: 582.92 lbs.
DOES NOT INCLUDE WEIGHT OF POWER OR PACKAGING!!!

*** ANY ADDITIONS, DELETIONS, OR OMISSIONS MUST BE CORRECTED ON THIS DRAWING AS THIS DRAWING WILL BE CONSIDERED ALL INCLUSIVE ***
ALL GRAPHICS PROVIDED ARE FOR REFERENCE ONLY. IF CERTAIN DIMENSIONS ARE CRITICAL PLEASE VERIFY THOSE DIMENSIONS WITH YOUR SALESPERSON

STANDARD FEATURES

MODEL NUMBER: TCD-M-60-AC
USABLE CHUTE WIDTH: 20" MIN TO 27" MAX
USAGE CHUTE LENGTH: 27 1/8"

OVERALL LENGTH: 75 5/8"
OVERALL WIDTH: 46 1/16"
OVERALL HEIGHT: 77 9/16"

OVERALL ROTATED HEIGHT: 134 11/16"
MAXIMUM ROTATED ANGLE: 45°
DUMP HEIGHT: 60 3/8"

WORKS WITH MODEL# TH-32/64/95
AND 95-GLT TRASH CANS

UNIFORM CAPACITY IS 400 LBS

CASTERS:
FRONT: 8" X 2" GFN SWIVEL
REAR: 8" X 2" GFN RIGID

TWO ADJUSTABLE FLOOR LOCKS

POWER UNIT: 115 V AC SINGLE PHASE
CONTROL: HAND

SPECIAL FEATURES

NONE

DIMENSION TOLERANCE ± 1/4"

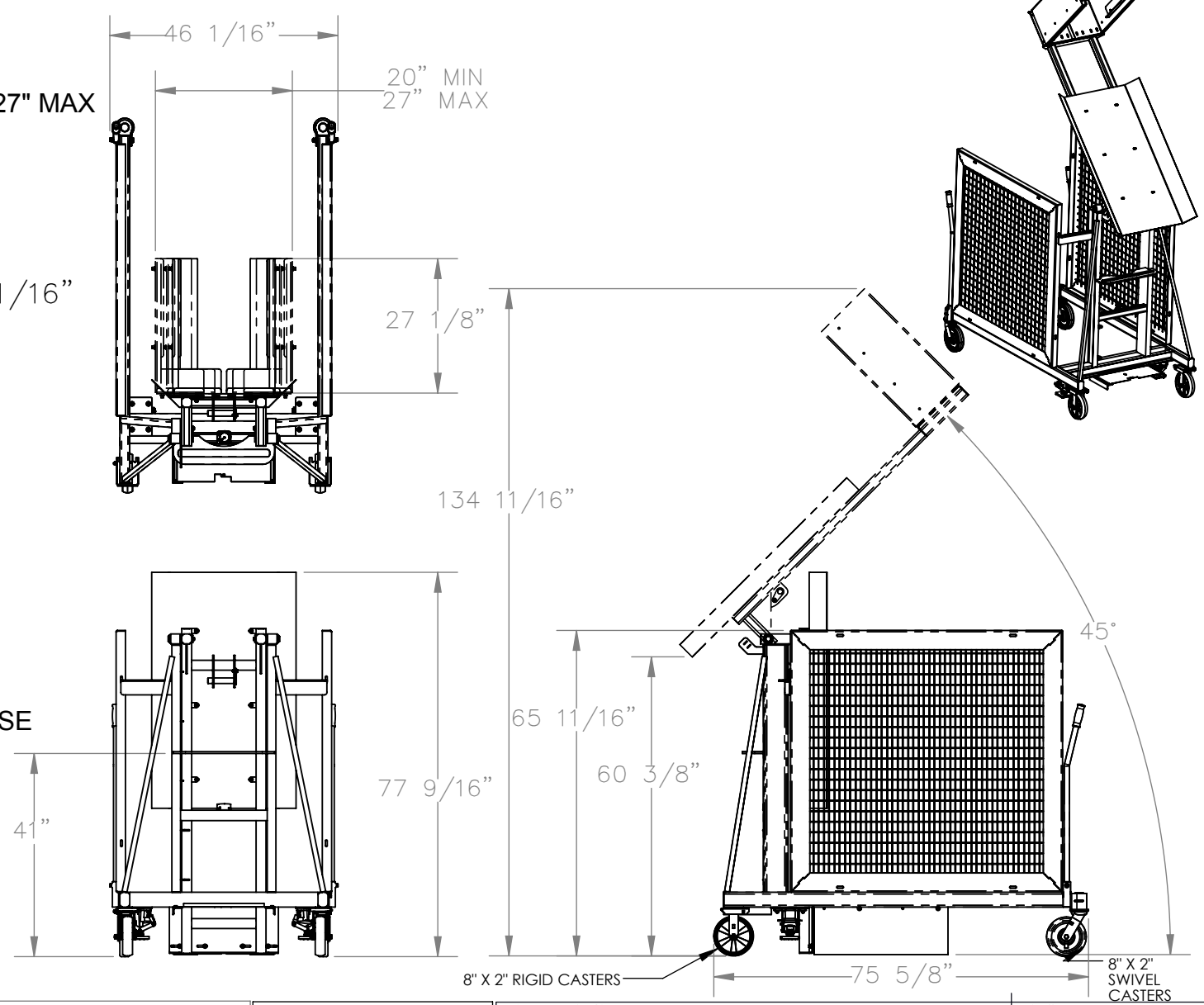

APPROVAL

I, THE UNDERSIGNED, AGREE THAT THE PRODUCT AS REPRESENTED SATISFIES DESIGN AND DIMENSION REQUIREMENTS. I ALSO ACKNOWLEDGE MY DUTY TO CONFIRM PRODUCT AND INSTALLATION COMPLIANCE WITH ALL APPLICABLE FEDERAL, STATE AND LOCAL REGULATIONS AND STANDARDS.

ANY MODIFIED UNITS ARE NON-RETURNABLE
[] As drawn [] As marked

Signed: _____ Date: _____
Printed Name: _____
LEAD TIME WILL START UPON RECEIPT OF SIGNED APPROVAL DRAWING

FOR INTERNAL USE ONLY PROJECT SIGN OFF	
SALES	
ENG.	
FAB.	
POWER	

DISTRIBUTOR'S NAME:
VESTIL MANUFACTURING

DRAWN BY: SJA DATE: 7/28/2016
REFERENCE: X SCALE: 1:32
QUOTED LEAD TIME: X QUOTE # X

P.O.# X
W.O.# X
SALES: X
FILE NAME:
34-007-029-001