

# AMERICAN CART & RACK

MANUFACTURED BY GRANITE INDUSTRIES

67129  
LANDSCAPE CART



1,300 LB



OUR CARTS  
HAUL  
MORE

PROUDLY  
MADE IN THE  
USA



BUILT  
HEAVY DUTY  
TO OUTLAST  
OTHERS



THREE  
YEAR  
LIMITED  
WARRANTY

## Features

- 16" pneumatic wheels for rough/uneven terrain
- Rock/Utility Tray (67130) may be added for more versatility
- 1,300 lb capacity

## STANDARD AMERICAN CART FEATURES

- **Made in the USA**  
Hand crafted at our Ohio plant.
- **Heavy-duty comes standard**  
American Carts are all built to heavy duty specs
- **Powder coated finish**  
Protects the steel and provides a lasting finish
- **Steel construction**  
Built from American sourced steel
- **Easy to operate**  
Designed to get work done with less muscle strain and simple operation.
- **Ready to ship**  
in stock and ready to ship
- **Three Year Limited Warranty**



Shown with Rock/  
Utility Tray (67130)



# AMERICAN CART & RACK

MANUFACTURED BY GRANITE INDUSTRIES

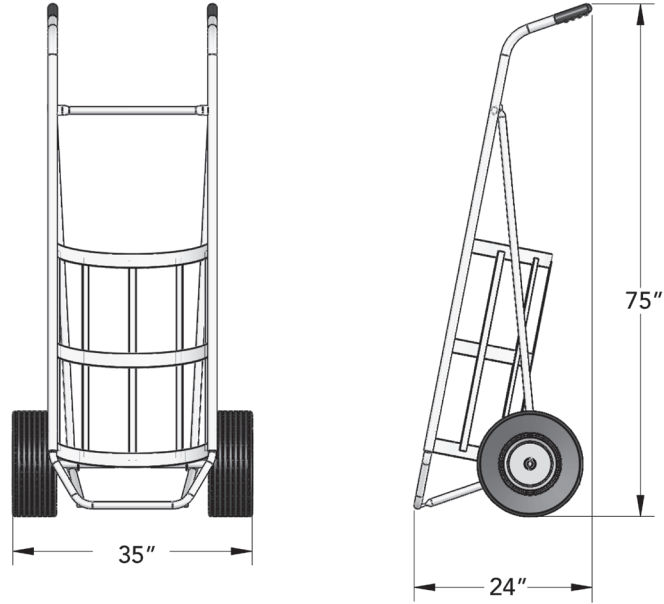

<b>Dimensions:</b>	<b>W:</b> 35"	<b>D:</b> 24"	<b>H:</b> 75"
<b>Weight:</b>	69 lbs.	<b>Capacity:</b>	1300 lbs.
<b>Typically Ships:</b>	Freight; fully assembled		

## ESTIMATED PALLETED SPECS

<b>Dimensions:</b>	<b>W:</b> 24"	<b>D:</b> 40"	<b>H:</b> 80"
<b>Weight</b>	89 lbs.		